

# Bobcat E55 Mini Excavator

## Key Specifications

Horsepower	48.8 hp
Operating Weight	12,312 lb
Dig Depth	12 ft 10 in

## Excavator

Series	M
Tail Swing Type	Conventional
Tail Swing Overhang	1 ft 1.4 inch
Weight	12,312 lb
Dig Depth	12 ft 10.4 in
Reach at Ground Level	19 ft 11.4 in
Dump Height Clearance	13 ft 6.7 in
Width	6 ft 5.1 in
Ground Pressure	4.49 psi
Standard Track Width	1 ft 3.7 in

## Performance

Arm Breakout Force	5750 lbf
Bucket Breakout Force	8976 lbf
Rated Lift Capacity	-
Over blade, ground level, 10ft. reach	5000 lb
Over side, ground level 10 ft. reach	2881 lb
Travel Speed: Low/High	1.92/3.1 mph

## Engine

Horsepower	48.8 hp
Engine Type	Interim Tier 4
Fuel Tank Capacity	21 gal

## Hydraulics

Piston Pump	Yes
Load-Sensing Pump	Yes

## Machine Features and Options

Angle Blade	Optional
Auto-Idle Throttle	Standard
Auto-Shift Travel System	Standard
Automatic Slew Brake	Standard
Blade Float	Standard
Cab with Heat	Optional (equipped)
Cab with Heat and A/C	Standard
Control Pattern Selector	Standard
Deluxe Cloth Seat	Optional
Fingertip Boom Swing Control	Standard
Keyless/Password Start system	Standard
Steel Tracks	Optional

## Features for Attachments

Auxiliary Hydraulics with Quick Couplers	Standard
Auxiliary Hydraulic Flow	20 gal/min
Auxiliary Hydraulic Pressure	3046 psi
Fingertip Auxiliary Control	Standard
Secondary Auxiliary Hydraulics	Optional (Equipped)
Selectable Auxiliary Flow	Standard

## Working Range

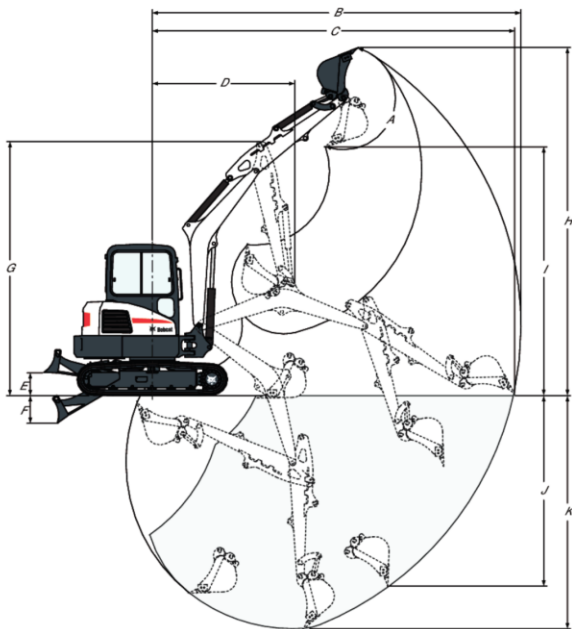

(A) 185.0°	(G) 187 in
(B) 243.7 in	(H) 320.3 in
(C) 239.5 in	(I) 164.5 in
(D) 94 in	(J) 125.9 in
(E) 15.2 in	(K) 154.5 in
(F) 18.3 in	

## Dimensions

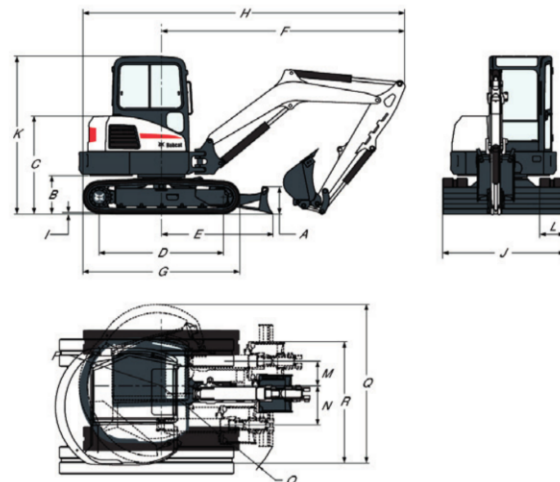

(A) 17.6 in	(J) 77.2 in
(B) 24.3 in	(K) 100 in
(C) 62 in	(L) 15.7 in
(D) 78.7 in	(M) 15.5 in
(E) 70.7 in	(N) 25 in
(F) 154.4 in	(O) 80.4 in
(G) 99.3 in	(P) 52 in
(H) 206.4	(Q) 90.2 in
(I) 0.98 in	(R) 87.5 in

Specifications taken from <https://www.bobcat.com/la/en/equipment/mini-excavators/5-10t-mini-excavators/e55>